



South Bay Foundry

WWW.SOUTHBAYFOUNDRY.COM

PHONE: (619) 956-2780 FAX: (619) 956-2788

SBF 1000

24" MANHOLE
FRAME AND COVER
DINUBA STORM SEWER SYSTEM

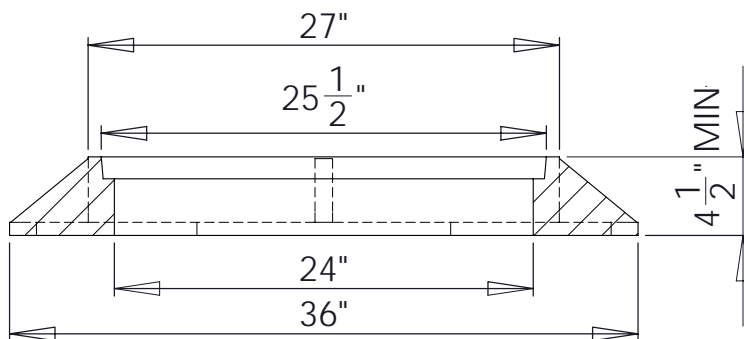
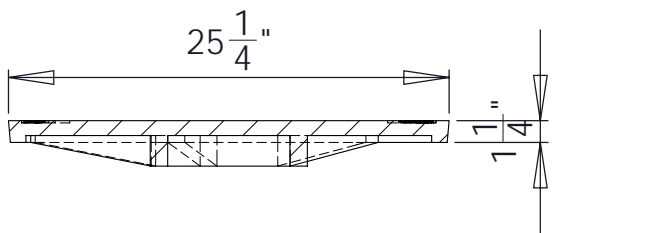
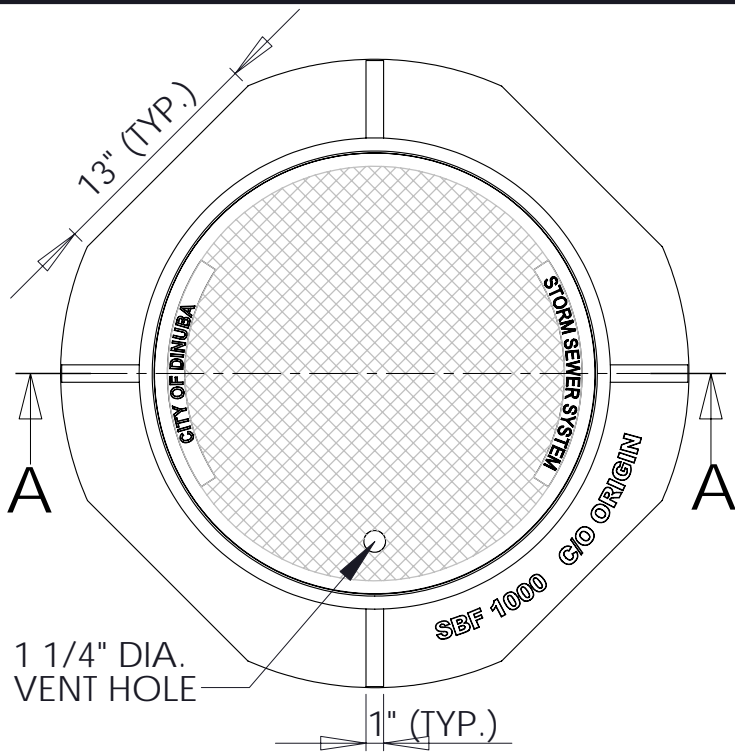

SECTION A-A

SET WEIGHT	
FRAME	180
COVER	147
TOTAL	327

GENERAL INFORMATION

- *MATERIAL: GREY CAST IRON ASTM A48 CLASS 30B
- *BEARING SURFACES MACHINED FOR CLOSE, QUIET FIT
- *FINISH: DIPPED IN BLACK BITUMINOUS PAINT
- *MEETS H-20 WHEEL LOAD

APPROVED

BY:

TITLE:

AGENCY:

DATE: